



## 500 Series Profile Rail Enhanced Carriage

### New, 66% Smoother Running Design, with 50% Lower Drag Force\*

### New Ball Spacer and Stainless Steel Options

#### Features and Benefits

Now available in all sizes: the new Thomson 500 Series Profile Rail enhanced carriage design can improve the smoothness and precision of your linear motion application. New optional 440B stainless carriages and rails provide corrosion resistance well-suited for medical, food, electronic assembly and semiconductor applications.

- New ball spacer carriage option provides smooth, quiet motion.
- New, smoother running design optimizes the surface interfaces between steel and plastic transition areas along the ball bearing circulation path.

- New standard end seals provide twice the contaminant protection compared to competitive products. Optional low drag end seals are ideal for low push force requirements.
- Four longitudinal seals per carriage provide much better contaminant protection than competitive designs with only two longitudinal seals.
- Additional lubrication reservoir enables longer running time and easy change end caps & seals are quick to replace.
- 100% interchangeable with previous Thomson 500 Series carriage and rail.

\* 66% smoothness increase measured as variability of drag force while the carriage is in motion. 50% lower drag force measured with new low drag seals option; 41% lower drag force measured with standard wiper option.

For Immediate assistance  
E-mail: [thomson@danahermotion.com](mailto:thomson@danahermotion.com)  
Tel. North America: +1-540-633-3549  
[www.thomsonlinear.com](http://www.thomsonlinear.com)

## 500 Series Ball Spacer

500 Series Ball Profile Rail carriages are now available with ball spacer elements that significantly reduce the running noise of the carriage. The ball spacer carriage is available in sizes 20, 25, 30, 35 and 45. It is a drop-in replacement for the current ball carriage; all external carriage dimensions are exactly the same.

The noise reduction is achieved by inserting plastic discs between each ball bearing. This reduces noise by preventing the balls from contacting each other as well as bumping into the ball track. The addition of the plastic discs requires a reduced number of load carrying balls, which leads to a slight reduction of the static and dynamic load capacity of the ball spacer carriage.



### Features and Benefits:

- Significant noise reduction (-6 dB)
- Minimum reduction of dynamic and static load capacity
- Drop-in replacement for 511 ball carriage
- Same accessory options as 511 ball carriage
- Better or identical performance in comparison to competitor push force and noise
- Carriage type designation: 513

Noise Measurement, 35mm Carriage

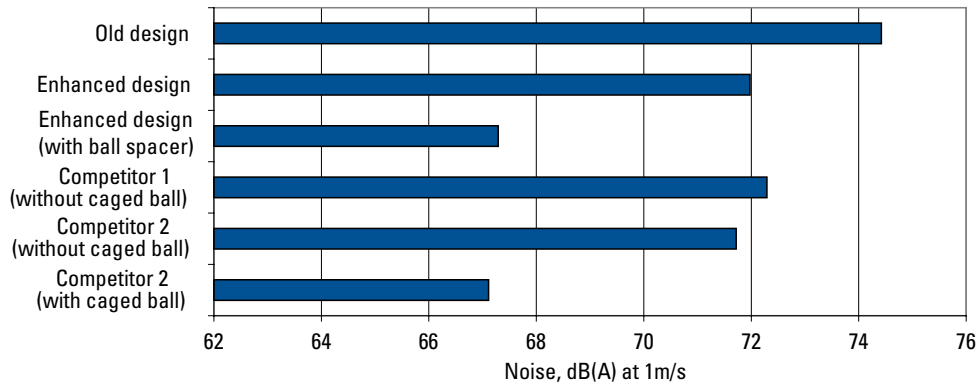

### Ball Spacer Technology Comparison

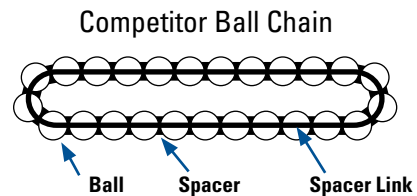
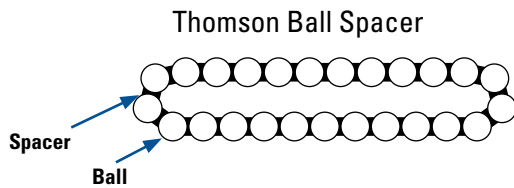

	Thomson 513 Ball Spacer	Competitor Ball Chain
<b>Internal Forces</b>	No tensile load	Tensile load on spacer links
<b>Quality</b>	Automatic inspection of each spacer element	Optical inspection not possible without bending link
<b>Balltrack clearances</b>	Any clearance between balls and spacers is minimized during assembly	Spacer link tolerances leads to undefined clearances
<b>Push Force</b>	Slight increase in push force	Significant increase in push force
<b>Reliability</b>	Fewer elements = fewer failure modes	Broken link elements can block re-circulation path

**500 Series Ball**  
511 / 513 Style A and B

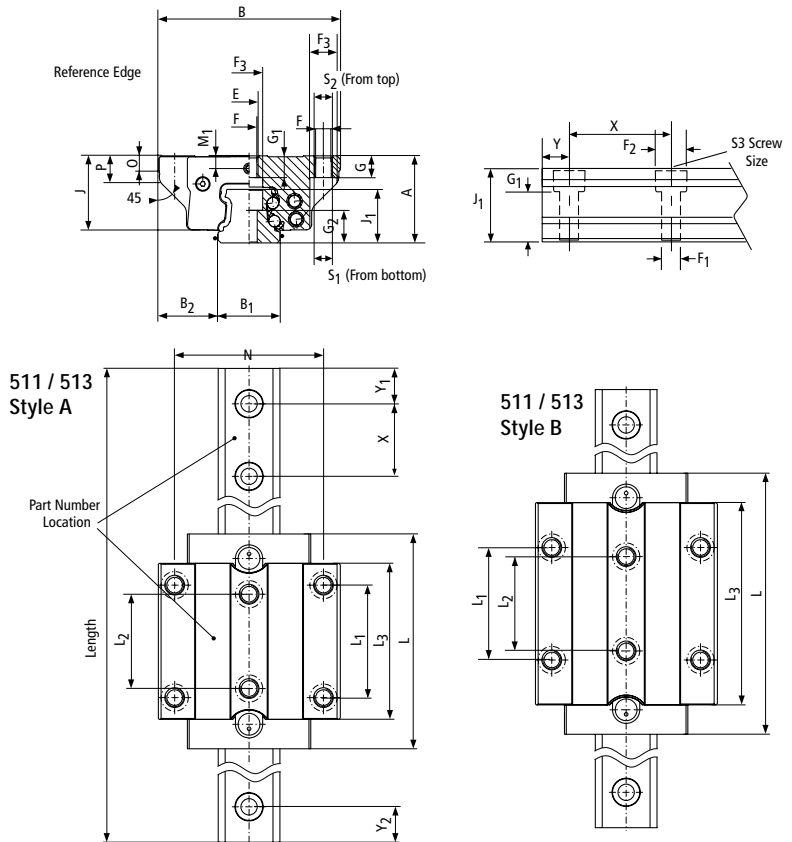

**511 / 513 Style A – Standard Ball**

Size	Dimensions (mm)							L	L <sub>1</sub>	L <sub>2</sub>	L <sub>3</sub>	X	N	S <sub>1</sub>	S <sub>2</sub>	S <sub>3</sub>	F	F <sub>1</sub>	F <sub>2</sub>	F <sub>3</sub>	Ball						
	A	B	B <sub>1</sub> *	B <sub>2</sub>	J	J <sub>1</sub>	Ø														G	G <sub>1</sub>	G <sub>2</sub>	M <sub>1</sub>	O	P	
15	24	47	15	16	20.2	15.7	56.6	30	26	39.6	60	38	M 5	M 5	M 4	4.4	4.5	8	7.5	3.2	7	4.5	9.5	4	7	7	
20	30	63	20	21.5	25.5	19	71.5	40	35	49.5	60	53	M 6	M 6	M 5	5.4	5.8	10	9.5	4.0	8	6.5	11.5	5.2	8	8	
25	36	70	23	23.5	30.5	22.7	84.5	45	40	59.5	60	57	M 8	M 8	M 6	6.8	7	11	11	4.8	9	8	14	5.5	7	11	
30	42	90	28	31	35.9	26	97.4	52	44	69.4	80	72	M 8	M 10	M 8	8.5	9	15	15	5.6	12	10	14.5	7	8	12	
35	48	100	34	33	41	29.5	111.6	62	52	79.6	80	82	M 10	M 10	M 8	8.5	9	15	15	6.4	12	12	18	7	8	14	
45	60	120	45	37.5	50.8	37	137.1	80	60	99.1	105	100	M 12	M 12	M 12	10.5	14	20	18	7.9	15	15	22	8	10	17.5	

**511 / 513 Style B – Standard Long Ball**

Size	Dimensions (mm)							L	L <sub>1</sub>	L <sub>2</sub>	L <sub>3</sub>	X	N	S <sub>1</sub>	S <sub>2</sub>	S <sub>3</sub>	F	F <sub>1</sub>	F <sub>2</sub>	F <sub>3</sub>	Ball						
	A	B	B <sub>1</sub> *	B <sub>2</sub>	J	J <sub>1</sub>	Ø														G	G <sub>1</sub>	G <sub>2</sub>	M <sub>1</sub>	O	P	
20	30	63	20	21.5	25.5	19	87.5	40	35	65.5	60	53	M 6	M 6	M 5	5.4	5.8	10	9.5	4.0	8	6.5	11.5	5.2	8	8	
25	36	70	23	23.5	30.5	22.7	103.5	45	40	78.5	60	57	M 8	M 8	M 6	6.8	7	11	11	4.8	9	8	14	5.5	7	11	
30	42	90	28	31	35.9	26	119.4	52	44	91.4	80	72	M 10	M 10	M 8	8.5	9	15	15	5.6	12	10	14.5	7	8	12	
35	48	100	34	33	41	29.5	137.1	62	52	105.1	80	82	M 10	M 10	M 8	8.5	9	15	15	6.4	12	12	18	7	8	14	
45	60	120	45	37.5	50.8	37	168.6	80	60	130.6	105	100	M 12	M 12	M 12	10.5	14	20	18	7.9	15	15	22	8	10	17.5	

\* Standard tolerance shown, special lower tolerances are available upon request. Please consult application engineering for additional information.

**500 Series Ball**  
511 / 513 Style C and D

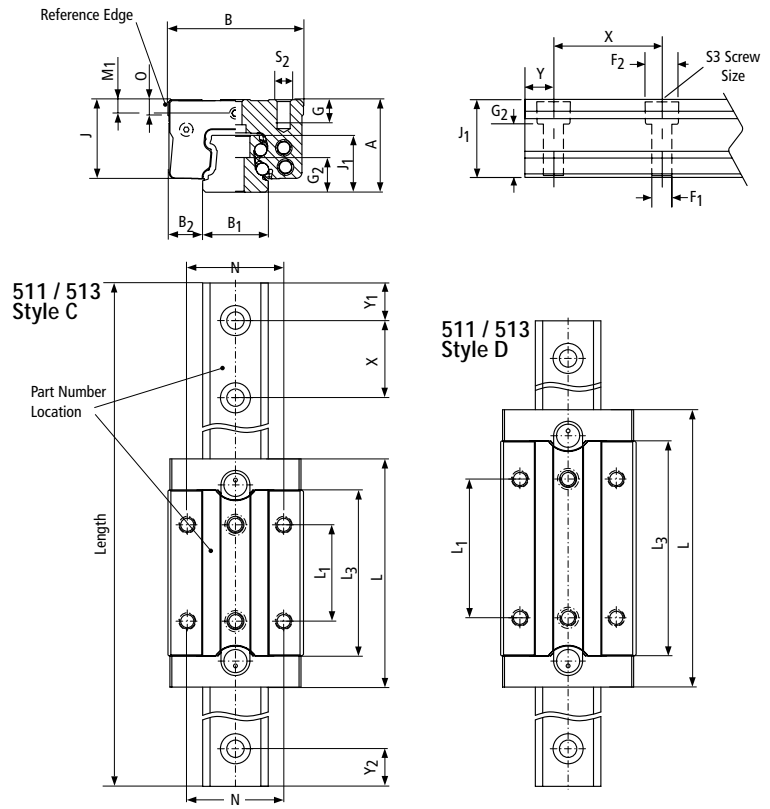

**511 / 513 Style C Narrow**

Size	Dimensions (mm)			B <sub>2</sub>	J	J <sub>1</sub>	L	L <sub>1</sub>	L <sub>3</sub>	X	N	S <sub>2</sub> /S <sub>3</sub>	F <sub>1</sub>	F <sub>2</sub>	Ball Ø	G	G <sub>2</sub>	M <sub>1</sub>	O
	A	B +0.4 -0.0	B <sub>1</sub> * +0.05																
15	24	34	15	9.5	20.2	15.7	56.6	26	39.6	60	26	M 4	4.5	8	3.2	5	9.5	4	5.5
20	30	44	20	12	25.5	19	71.5	36	49.5	60	32	M 5	5.8	10	4.0	7	11.5	5.2	6
25	36	48	23	12.5	30.5	22.7	84.5	35	59.5	60	35	M 6	7	11	4.8	9	14	5.5	7.5
30	42	60	28	16	35.9	26	97.4	40	69.4	80	40	M 8	9	15	5.6	11	14.5	7	8
35	48	70	34	18	41	29.5	111.6	50	79.6	80	50	M 8	9	15	6.4	12	18	7	8

**511 / 513 Style D Narrow Long**

Size	Dimensions (mm)			B <sub>2</sub>	J	J <sub>1</sub>	L	L <sub>1</sub>	L <sub>3</sub>	X	N	S <sub>2</sub> /S <sub>3</sub>	F <sub>1</sub>	F <sub>2</sub>	Ball Ø	G	G <sub>2</sub>	M <sub>1</sub>	O
	A	B +0.4 -0.0	B <sub>1</sub> * +0.05																
20	30	44	20	12	25.5	19	87.5	50	65.5	69.5	32	M 5	5.8	10	4.0	7	11.5	5.2	6
25	36	48	23	12.5	30.5	22.7	103.5	50	78.5	60	35	M 6	7	11	4.8	9	14	5.5	7.5
30	42	60	28	16	35.9	26	119.4	60	91.4	80	40	M 8	9	15	5.6	11	14.5	7	8
35	48	70	34	18	41	29.5	137.1	72	105.1	80	50	M 8	9	15	6.4	12	18	7	8

\* Standard tolerance shown, special lower tolerances are available upon request. Please consult application engineering for additional information.

**500 Series Ball**  
511 / 513 Style E and F

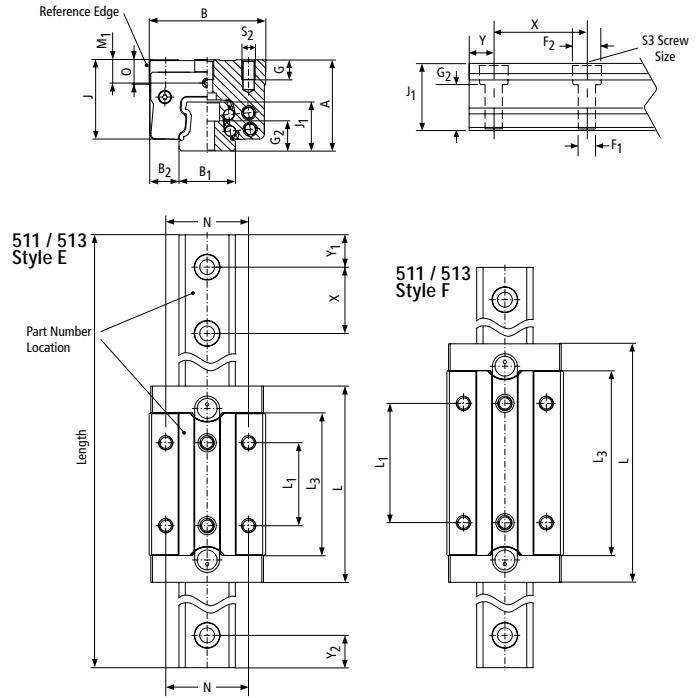

**511 / 513 Style E Narrow High**

Size	Dimensions (mm)			B <sub>2</sub>	J	J <sub>1</sub>	L	L <sub>1</sub>	L <sub>3</sub>	X	N	S <sub>2</sub> /S <sub>3</sub>	F <sub>1</sub>	F <sub>2</sub>	Ball Ø	G	G <sub>2</sub>	M <sub>1</sub>	O
	A	B +0.4 -0.0	B <sub>1</sub> * +0.05																
15	28	34	15	9.5	24.2	15.7	56.6	26	39.6	60	26	M 4	4.5	8	3.2	6	9.5	8	6
25	40	48	23	12.5	34.5	22.7	84.5	35	59.5	60	35	M 6	7	11	4.8	9	14	9.5	11
30	45	60	28	16	38.9	26	97.4	40	69.4	80	40	M 8	9	15	5.6	11	14.5	10	11
35	55	70	34	18	48	29.5	111.6	50	79.6	80	50	M 8	9	15	6.4	12	18	14	15
45	70	86	45	20.5	60.8	37	137.1	60	99.1	105	60	M 10	14	20	7.9	18	22	18	19

**511 / 513 Style F Narrow Long High**

Size	Dimensions (mm)			B <sub>2</sub>	J	J <sub>1</sub>	L	L <sub>1</sub>	L <sub>3</sub>	X	N	S <sub>2</sub> /S <sub>3</sub>	F <sub>1</sub>	F <sub>2</sub>	Ball Ø	G	G <sub>2</sub>	M <sub>1</sub>	O
	A	B +0.4 -0.0	B <sub>1</sub> * +0.05																
25	40	48	23	12.5	34.5	22.7	103.5	50	78.5	60	35	M 6	7	11	4.8	9	14	9.5	11
30	45	60	28	16	38.9	26	119.4	60	91.4	80	40	M 8	9	15	5.6	11	14.5	10	11
35	55	70	34	18	48	29.5	137.1	72	105.1	80	50	M 8	9	15	6.4	12	18	14	15
45	70	86	45	20.5	60.8	37	168.6	80	130.6	105	60	M 10	14	20	7.9	18	22	18	19

\*Standard tolerance shown, special lower tolerances are available upon request. Please consult application engineering for additional information.

**500 Series Ball  
511 Style G**

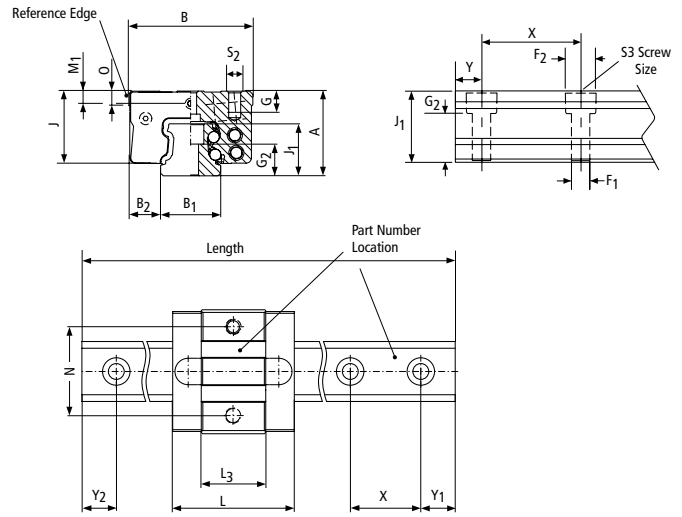
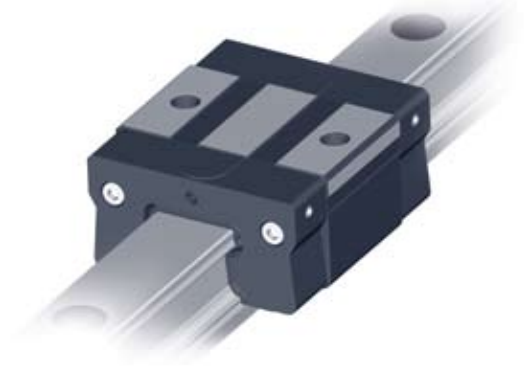

**511 Style G Narrow Short**

Size	Dimensions (mm)																	
	A	B +0.4 -0.0	B <sub>1</sub> * +0.05	B <sub>2</sub>	J	J <sub>1</sub>	L	L <sub>3</sub>	X	N	S <sub>2</sub> /S <sub>3</sub>	F <sub>1</sub>	F <sub>2</sub>	Ball Ø	G	G <sub>2</sub>	M <sub>1</sub>	O
15	24	34	15	9.5	20.2	15.7	37.6	20.6	60	26	M4	4.5	8	3.2	6	9.5	4	6
20	28	44	20	12	23.5	19	47.7	25.7	60	32	M5	5.8	10	4.0	6	11.5	4.2	4

\* Standard tolerance shown, special lower tolerances are available upon request. Please consult application engineering for additional information.

# 500 Series Ball

## Part Numbering Description

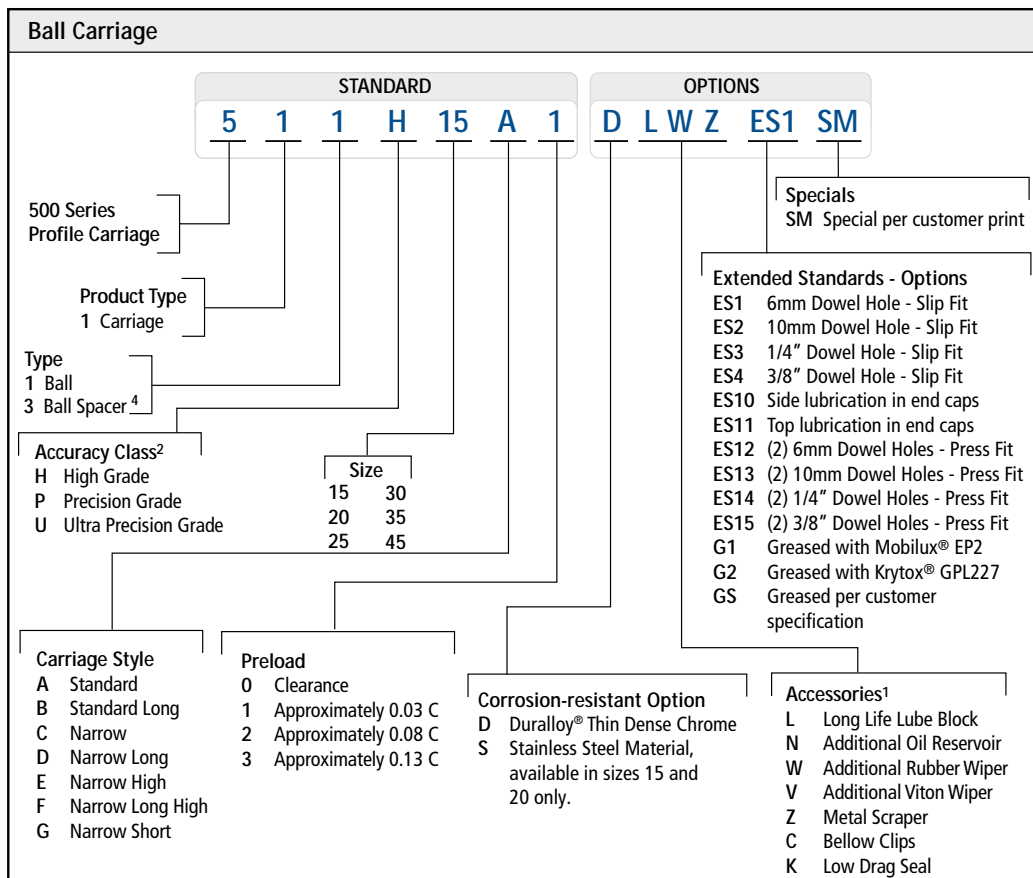

1. Accessory combination part numbers are listed from carriage end cap outward. Not all combinations are available. For specific combination availability see pages 33-34 of the Profile Rail Linear Guide Catalog or consult Danaher Motion.

2. The 500 Series Ball lowest accuracy grade is High as a result of tight manufacturing controls and grinding capabilities. We do not offer Normal grade accuracy, our High grade is our Normal grade.

3. New enhanced carriage does not retain ball bearings when end cap is removed. Removal of end caps can result in loss of ball bearings.

4. Ball Spacer carriage not available in size 15.

# 500 Series Ball

## Part Numbering Description

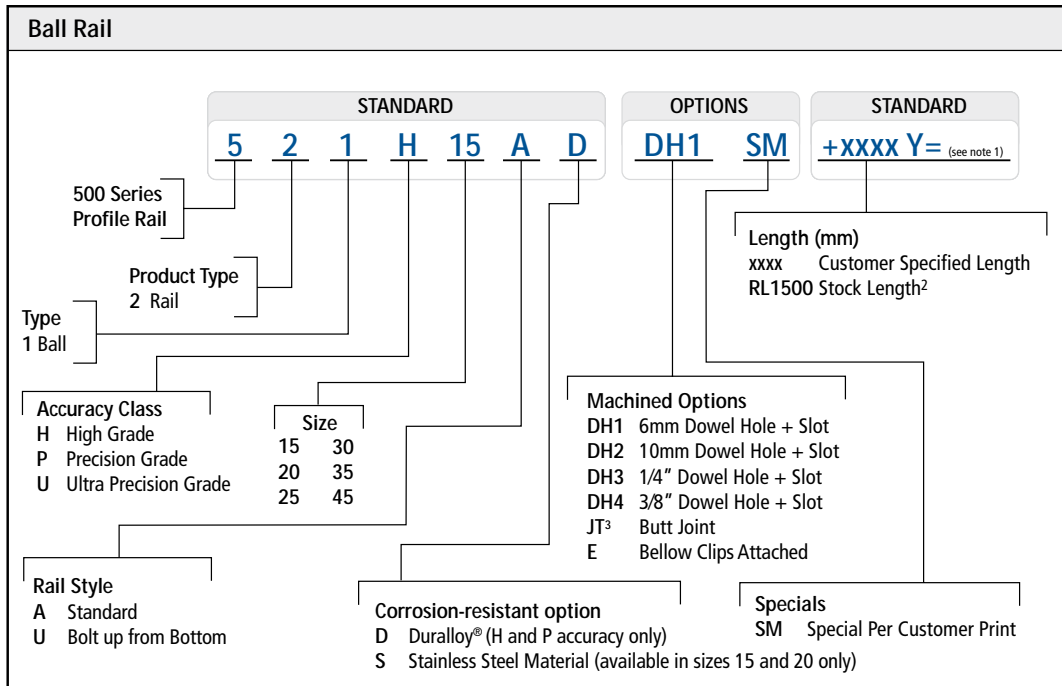

- Y = Distance from end of rail to center of first mounting hole, Y1 = Y2 unless specified
- Stock length rails are considered random length, total length may exceed specified length, and Y1/Y2 are not equal. To be used by customer who will cut to length.
- Customer drawing required at time of quote and order. See page 112 of Profile Rail Linear Guide Catalog for more information and templates.

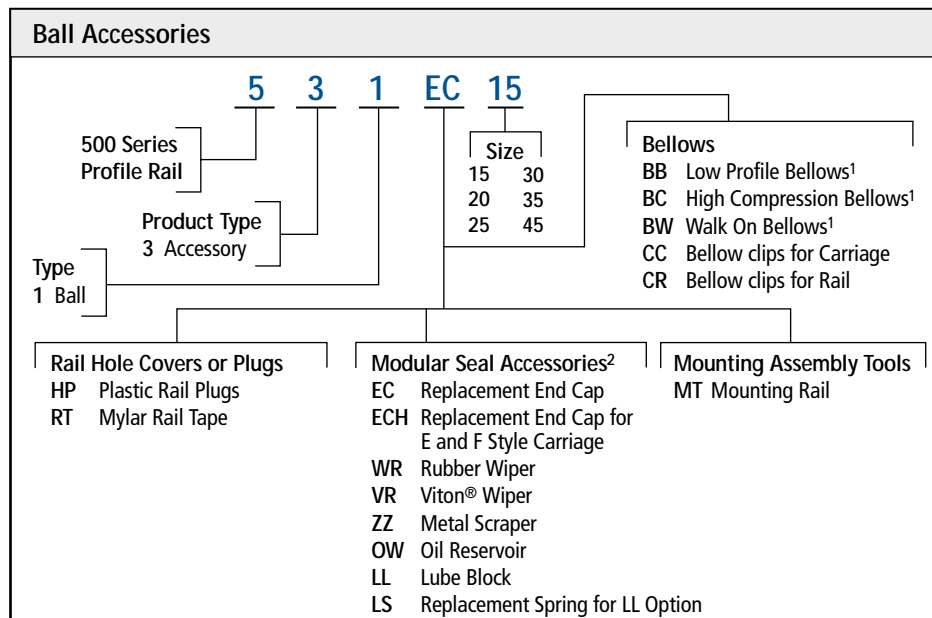

- Bellows and rail cover strip must include length at time of order. Example: 531BB15 + 1000mm. See page 111 of Profile Rail Linear Guides Catalog on how to calculate bellows length.
- Two standard screws included with each item. Screws for attaching this accessory to carriage and not combinations of accessories.

200802-12 TPS SK 1-2009 USA  
 Specifications are subject to change without notice. It is the responsibility of the product user to determine the suitability of this product for a specific application. All trademarks property of their respective owners.  
 © Thomson 2009